



Sparrows BSM Engenharia Ltda

Sparrows BSM Engenharia é uma joint venture estabelecida em 2002 em Macaé, Brasil, para atender a uma crescente demanda por serviços na área de guindastes offshore, onshore e portuários, oferecendo soluções de engenharia de manutenção e operações de guindastes, bem como treinamento em manuseio de carga para o mercado brasileiro.

Como resultado da joint venture entre BSM Engenharia, uma conhecida empresa de aluguel de guindastes e movimentação de carga fundada no Rio de Janeiro em 1973, e o Sparrows Group, fundado em 1974 em Aberdeen, Escócia, no SparrowsBSM tem uma equipe altamente especializada em operações ao redor do Mundo, com vasta experiência em serviços e soluções, além de possuir certificações de diversas instituições classificadoras ao redor do mundo, como a DNV AG, ABS, OPITO. E no Brasil, é credenciado no sistema ISO 9.001, 14.001 e 45.001.

Total de Área 3000m²



Workshop / Oficina



Certificações

Na SPARROWS BSM somos comprometidos com a saúde, segurança, meio ambiente e qualidade, além de sermos certificados nas ISOS 9001, 14001 e 45001, DROPS, DNV GL e LEEA.



Lifting Equipment
Engineers Association
Lifting Standards Worldwide™



DROPS
DROPPED OBJECTS
PREVENTION SCHEME



EBANC
Empresa Brasileira Acreditadora de Norma de Compliance

Teste de Carga de Guindaste

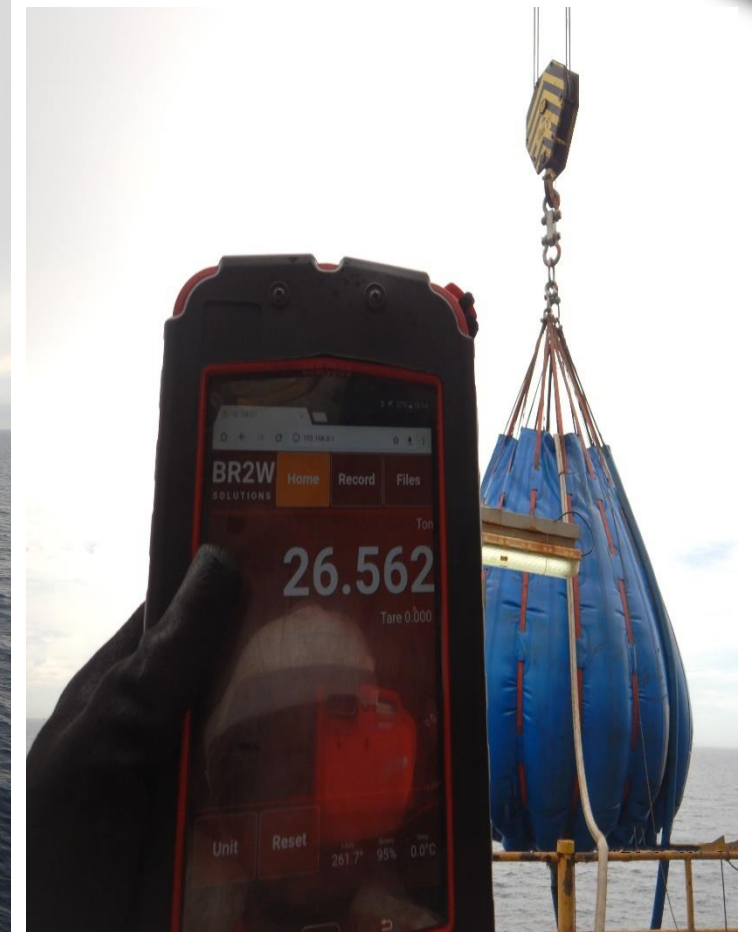

Bancada de Teste de Carga

TESTE E CERTIFICAÇÃO

- Testamos e certificamos os mais diversos equipamentos e dispositivos de elevação e movimentação de cargas, com capacidade de testes de até 300 toneladas.



Recertificação de Ponte Rolante

- Inspeção
- Documentos
- Verificação geral
- Controles e comandos
- Colunas
- Trilhos e estruturas de içamento
- Carros trole
- Talhas e ganchos
- Guinchos, redutoras e motores
- Painéis elétricos e cabeamentos
- Cabos de aço



Departamento de Engenharia

A **SPARROWS BSM** conta com o Departamento de Engenharia composto por profissionais qualificados em desenvolver soluções relacionadas aos serviços, On e Offshore, Siderurgia, Mineração, Agro, Ambiental e Eólicas.

- Planejamento e movimentação de cargas
- Projetos
- Fabricação e montagem de equipamentos
- Análise estrutural

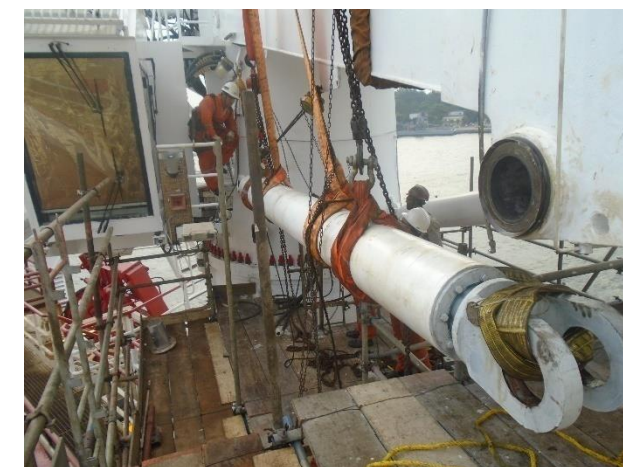
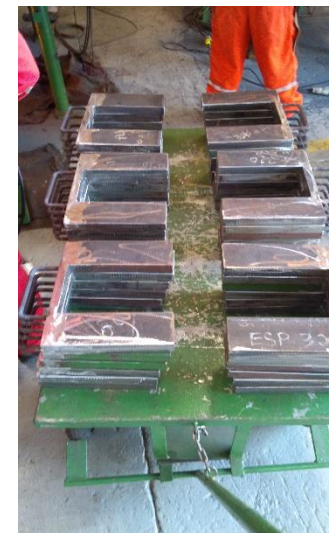

Projetos

- Desenvolvimento de equipamentos especiais

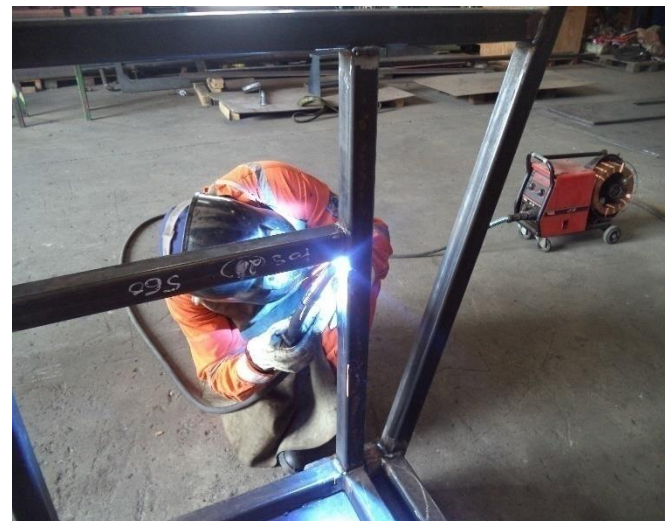
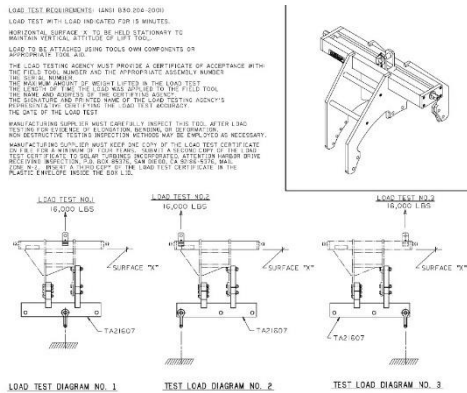

Recertificação de Talhas

- Inspeção visual
- Aberturas dos ganchos
- Trincas
- Corrosão excessiva
- Inspeção das correntes
- Inspeção dos pinos de carga
- Ensaio não destrutivo
- Teste de carga

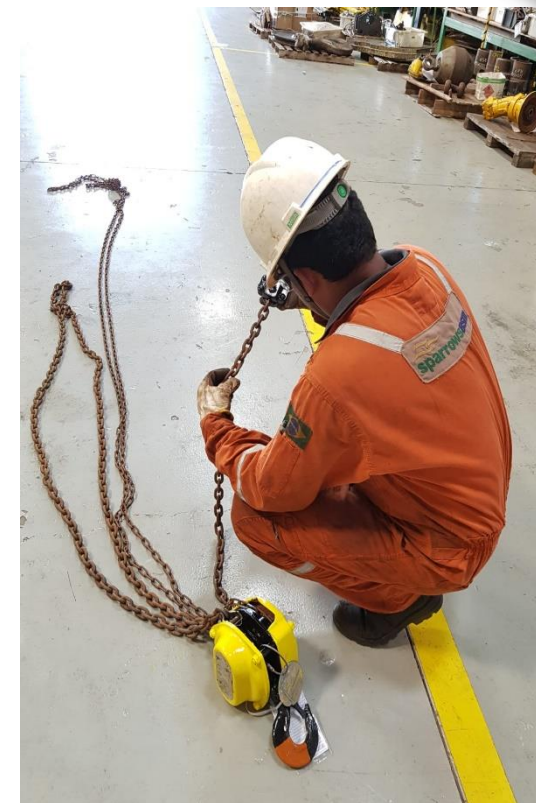
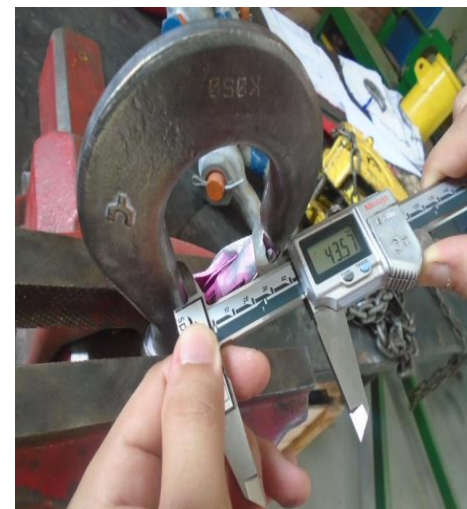
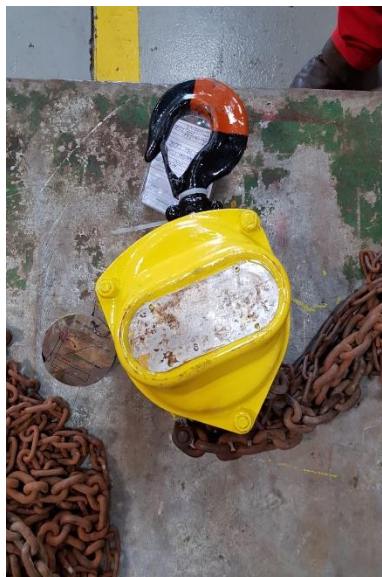

Manutenção e Recertificação de Equipamentos

- Manilhas
- Cintas
- Anelões
- Patescas
- Olhais
- Soquetes
- Eslingas
- Cabo de aço
- Tirfor
- Troler
- Skids
- Caixas metálicas
- Contêineres

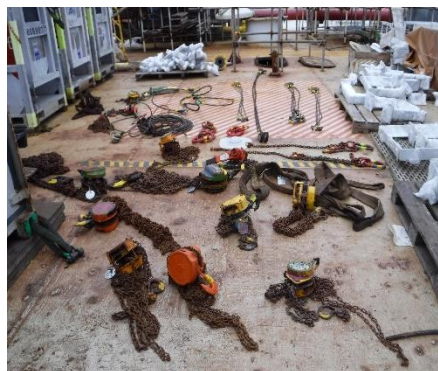
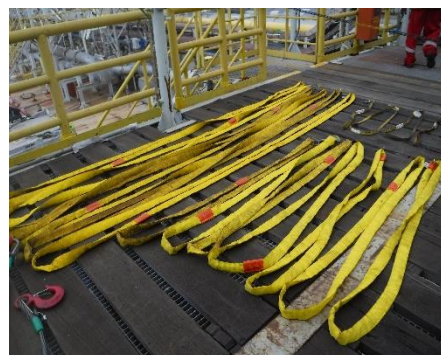
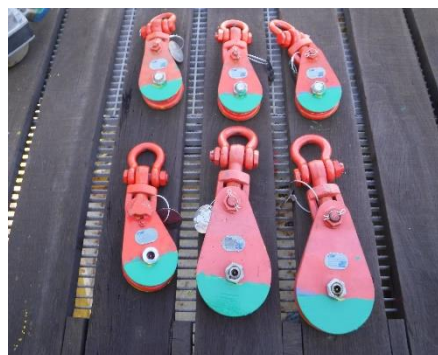
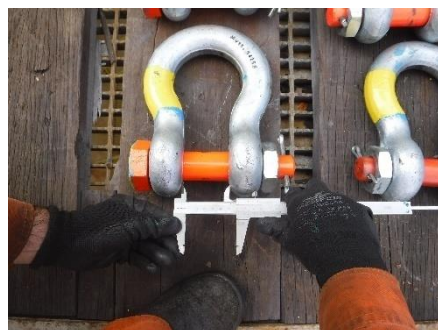

Manutenção de Guinchos

- Desmontagem do equipamento
- Separação dos componentes
- Separação de peças críticas (Rolamentos, vedações, porcas e parafusos)
- Ensaio NDT
- Jateamento
- Pintura padrão offshore
- Teste de carga
- Remontagem



Recertificação e Manutenção de Moitões





- Inspeção de campo
- Elaboração e atualização de PIE
- Check list NR10
- Plano de recomendação
- Reparos e adequações



Ensaios e Inspeções NDT

- Inspeção por líquido penetrante
- Inspeção por partícula magnética
- Inspeção por bobina
- Inspeção por corrente parasita
- Inspeção por ultrassom
- Inspeção boroscópica
- Medição de espessura



Contêiner Oficina 10/20 ft

Pensando na total comodidade dos nossos clientes disponibilizamos de contêiner oficinas para serviços onshore/offshore

- Consumíveis certificados
- Equipamentos certificados
- Técnicos qualificados

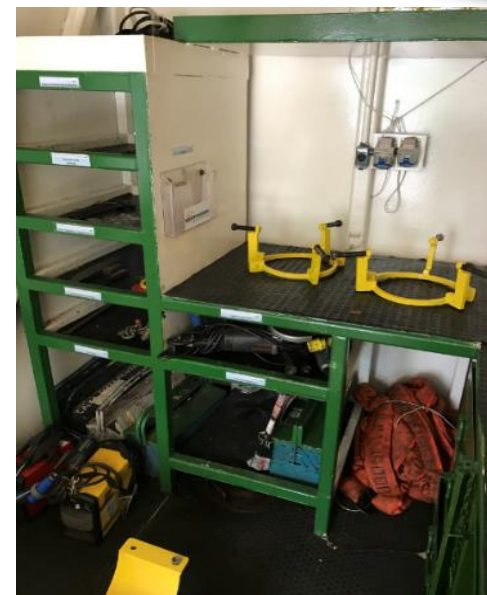

Sumário:

- Nosso centro de treinamento;
- Salas de treinamentos:
 - *Treinamentos certificados pela PETROBRAS;*
 - *Operador de guindaste;*
 - *Inspeção de cabos de aço;*
 - *Soquetagem;*
 - *Treinamento em NR's;*
- Mão de obra especializada: Operadores de guindaste offshore

Centro de Treinamento

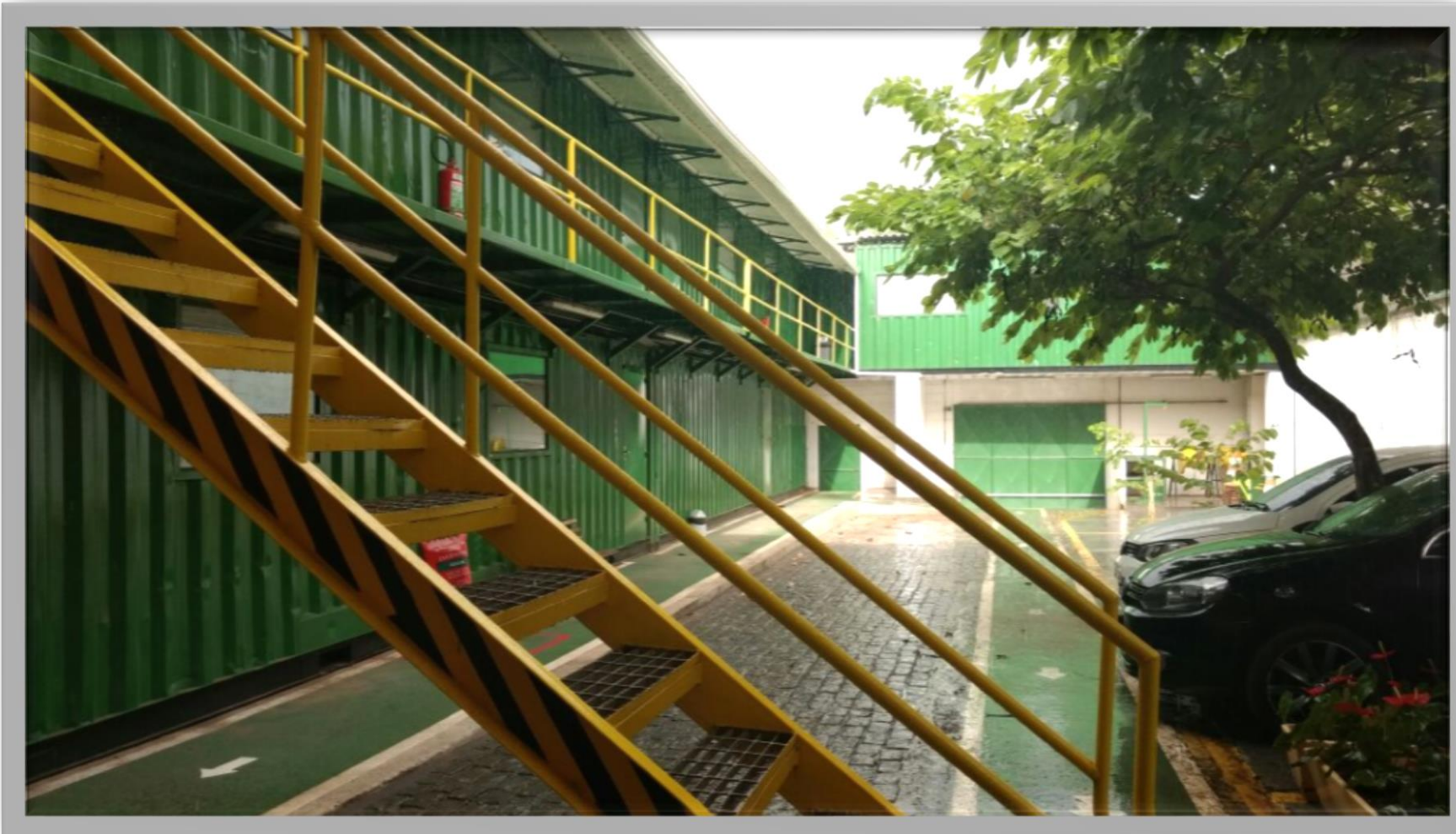

Sala de Treinamento



Treinamentos

Consultorias Especializadas em Movimentação de Cargas e Operação de Guindaste:

Serviço desenvolvido sobre medida para o cliente, visando incutir segurança e familiaridade na utilização dos recursos disponibilizados pela empresa – o que resulta em aumento de performance da equipe.

- Motivar e direcionar as atividades de movimentação de cargas de acordo com os padrões de segurança pré-estabelecidos pela empresa;
- Revisão de procedimentos utilizados;
- Verificação de eficiência dos procedimentos;
- Mapeamento de perfis X Recursos motivacionais;
- Familiarização de Operadores de Guindastes Offshore
 - Modelo específico de guindaste;
- Avaliação de Equipe;
- Suporte Operacional;



Operador de Guindaste

Treinamentos *Padrão BS 7121:*

- Operador de guindaste offshore – Nível 1 (sem validade)
- Operador de guindaste offshore – Nível 2
- Operador de guindaste offshore – Nível 3

Nível 1

Operadores Principiantes
Desenvolvido para pessoas que não possuem experiência prévia para operar sob supervisão para desenvolvimento das habilidades



Nível 2

Operadores experientes –
Içamento estático
Desenvolvido para pessoal com no mínimo 2 anos de experiência para realizar içamentos no deck

Nível 3

Operadores experientes –
Içamento dinâmico
Avaliação de competência conduzida por um instrutor Sparrows a bordo de uma unidade offshore



Nível 3

Reassessment
Recertificação
Manutenção de certificação para operadores nível 3. Pode ser realizado a bordo de uma unidade offshore ou em nosso simulador de operações

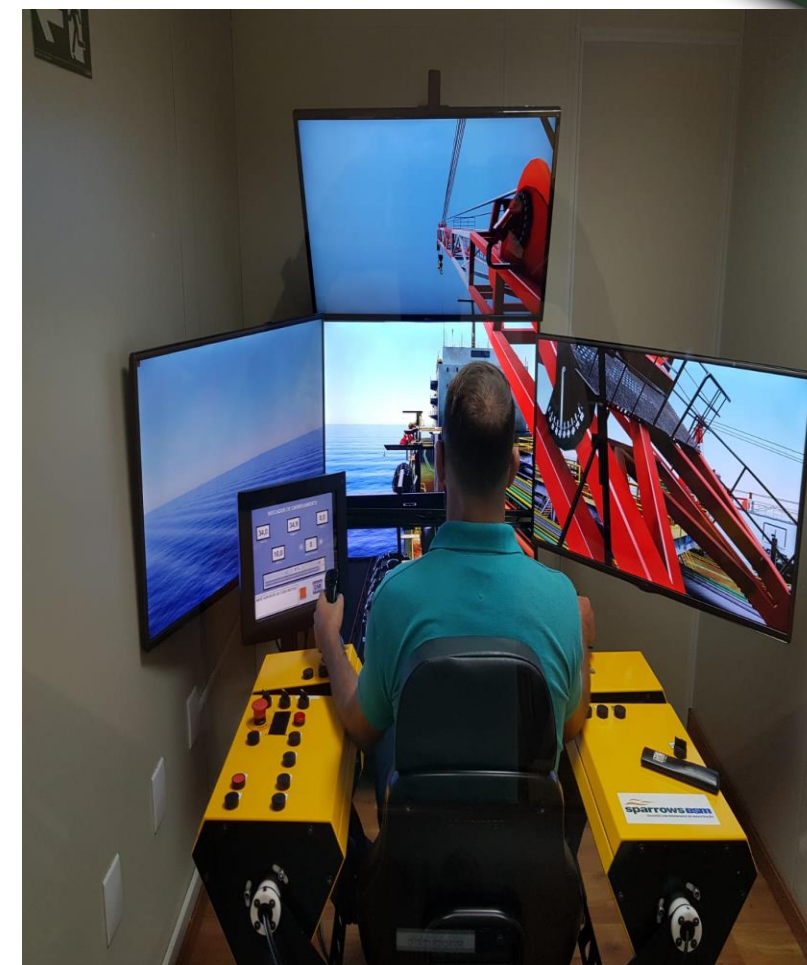

Outros Treinamentos

Treinamentos Especializados em Inspeção de Cabos de Aço:

- Movimentação de cargas – 20h
- Movimentação de cargas e inspeção em cabos de aço – 40h
- Segurança na operação de empilhadeiras;
- Segurança na operação de pontes rolantes;
- Treinamento de operação de Frog;
- Manutenção de guindastes offshore – básica;
- Substituição de cabos de aço;

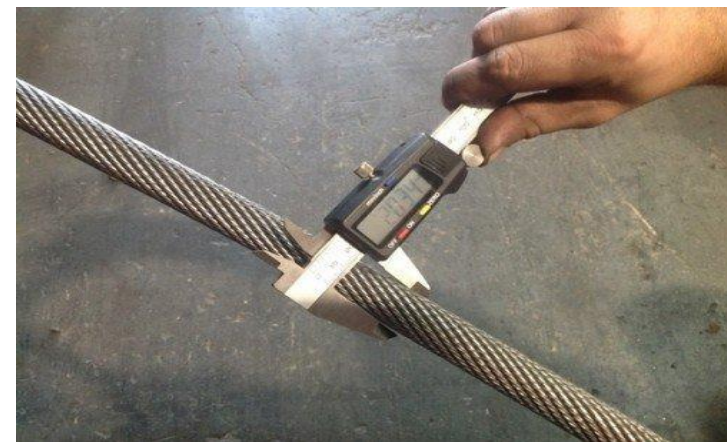

Soquetagem

- Soquetagem consiste em realizar a reterminação em cabos de aço, sendo assim garante a segurança da operação de acordo com a norma ABNT-NBR11900-5 de 11/2015.
- Procedimentos
- Limpeza do soquete
- Abertura da vassoura
- Descontaminação dos fios
- Isolamento do cabo
- Aplicação da resina
- Secagem
- Teste de carga



Treinamentos em NR's

Treinamentos em NR's:

- NR-05 CIPA;
- NR- 06 EPI
- NR-11 Ponte rolante/ Empilhadeira (in company);
- NR-33 (8H, 16H) Espaço confinado;
- NR-34/37;
- NR-35 trabalho em altura;



Representações

 reflexmarine



MIPEG

CRANE SAFETY AND MONITORING SYSTEMS



ITALGRU
PORT & OFFSHORE CRANES

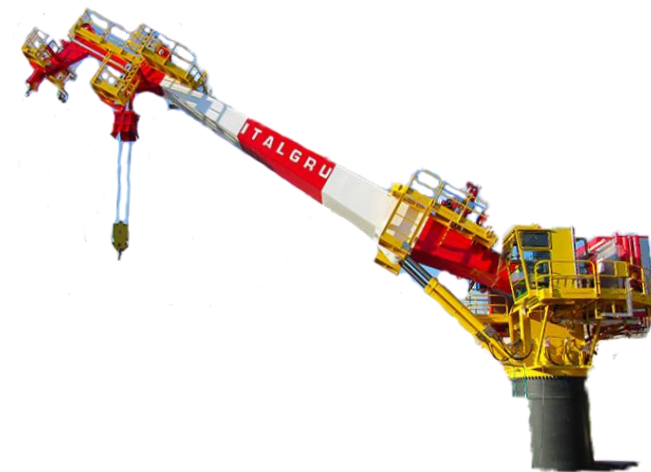

Nossos Clientes



Contatos Comerciais

Serviços ; Onshore/Offshore

Fabio Beanchine Fraguas

Commercial Technical Analyst



t: [+55 22 2106-4556](tel:+552221064556)
m: [+55 22 99279-5393](tel:+5522992795393)
e: Fabio.beanchine@sparrowsbsm.com.br
i: www.sparrowsbsm.com.br

Pedro Orro

Contracts Manager



t: [+55 22 2106-4588](tel:+552221064588)
m: [+55 22 99261-0767](tel:+5522992610767)
e: pedro.orro@sparrowsbsm.com.br
i: www.sparrowsbsm.com.br

Cursos/Treinamentos

Caroline Schmidt

Training Coordinator



t: [+55 22 2106-4585](tel:+552221064585)
m: [+55 22 99267-6445](tel:+5522992676445)
e: caroline.schmidt@sparrowsbsm.com.br
i: www.sparrowsbsm.com.br

RIO: R2X GROUP



m: [+55 21 96923-1878](tel:+5521969231878)
e: Joaquim@r2x.com.br
i: www.r2x.com.br